

<b>SPEC. INFO</b>	<b>FL-CC0820-5MX</b>	
		Aug. 30, 2019

1. Model FL-CC0820-5MX
2. Application For 2/3 Format Camera
3. Specification



3-1. Physical (As per the attached drawing)

- (1) Dimensions  $\phi$  33.0 mm  $\times$  43.0 mm
- (2) Weight 78 g
- (3) Mount C-Mount (1 – 32 UN – 2A)
- (4) Filter Screw Size M30.5 mm , P = 0.5 mm

3-2. Optical

- (1) Focal Length 8 mm  $\pm$  5%
- (2) Max. Aperture Ratio 1: 2.0
- (3) Iris Range F / 2.0 to F / 16
- (4) Angle of View
  - Diagonal 70.1°
  - Horizontal 58.5°
  - Vertical 45.3°
- (5) Picture format 8.8 mm  $\times$  6.6 mm
- (6) Focusing Range Inf. to 0.1 m
- (7) Back Focal Length 13.0 mm (in air)
- (8) Flange Back Length 17.526 mm  $\pm$  0.05 mm (in air)

3-3. Mechanical

- (1) Focusing Mechanism
  - Rotation Angle 56°
  - Rotation Torque 1.0N·cm to 9.0 N·cm
  - Focus Ring can be fixed at any positions by 3 fixing screws or 1 thumb screw (refer to external view)
- (2) Iris Mechanism
  - Non-click
  - Rotation Angle 83°
  - Rotation Torque 0.01N·cm to 3.0 N·cm
  - Iris Ring can be fixed at any positions by 3 fixing screws or 1 thumb screw (refer to external view)

3-4. Vibration & Shock Test Standard

(1) Vibration Conditions

Wave	Sine Wave
Acceleration	1.96 m/s <sup>2</sup> to 59.78 m/s <sup>2</sup>
Cycle Range	10 Hz to 55 Hz
Cycle Period	3 Minutes
Duration of Vibration	120 Minutes Respectively in Three Dimensional Directions

(2) Shock Conditions

Tester	Shock Testing Machine by Dropping
Impact Force	588 m/s <sup>2</sup>
Duration of Shock	3.5 ms
Directions & Number of Times	1 Time Respectively in Three Dimensional Directions

<b>SPEC. INFO</b>	<b>FL-CC0820-5MX</b>	
		Aug. 30. 2019

3-5. Environmental Temperature Range       $-10^{\circ}\text{C}$  to  $+50^{\circ}\text{C}$

4. Accessories

- |                                       |          |                      |
|---------------------------------------|----------|----------------------|
| (1) Front Lens Cap                    | 1 piece  |                      |
| (2) Rear Lens Cap                     | 1 piece  |                      |
| (3) Fixing Screw for Focus ,Iris Ring | 6 pieces |                      |
| (4) Thumbscrew for Focus ,Iris Ring   | 2 pieces | (for Optional Usage) |
| (5) Instruction Manual                | 1 sheet  |                      |
| (6) Packing Box                       | 1 piece  |                      |

**Vision Light Tech B.V.**

Protonenlaan 22, 5405 NE UDEN, P.O. Box 345, 5400 AH UDEN, The Netherlands

Phone: +31 (0)413 26 00 67, Fax +31 (0)413 26 09 38, E-mail: [inquiry@vlt.nl](mailto:inquiry@vlt.nl), Website: [www.vlt.nl](http://www.vlt.nl)

Trade register No. 17150044, VAT No. NL8112.30.946.B01

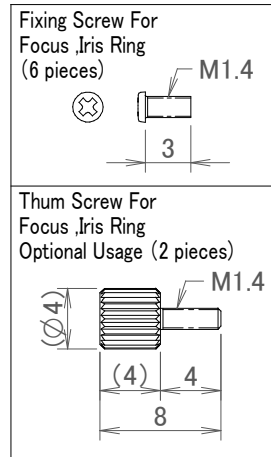
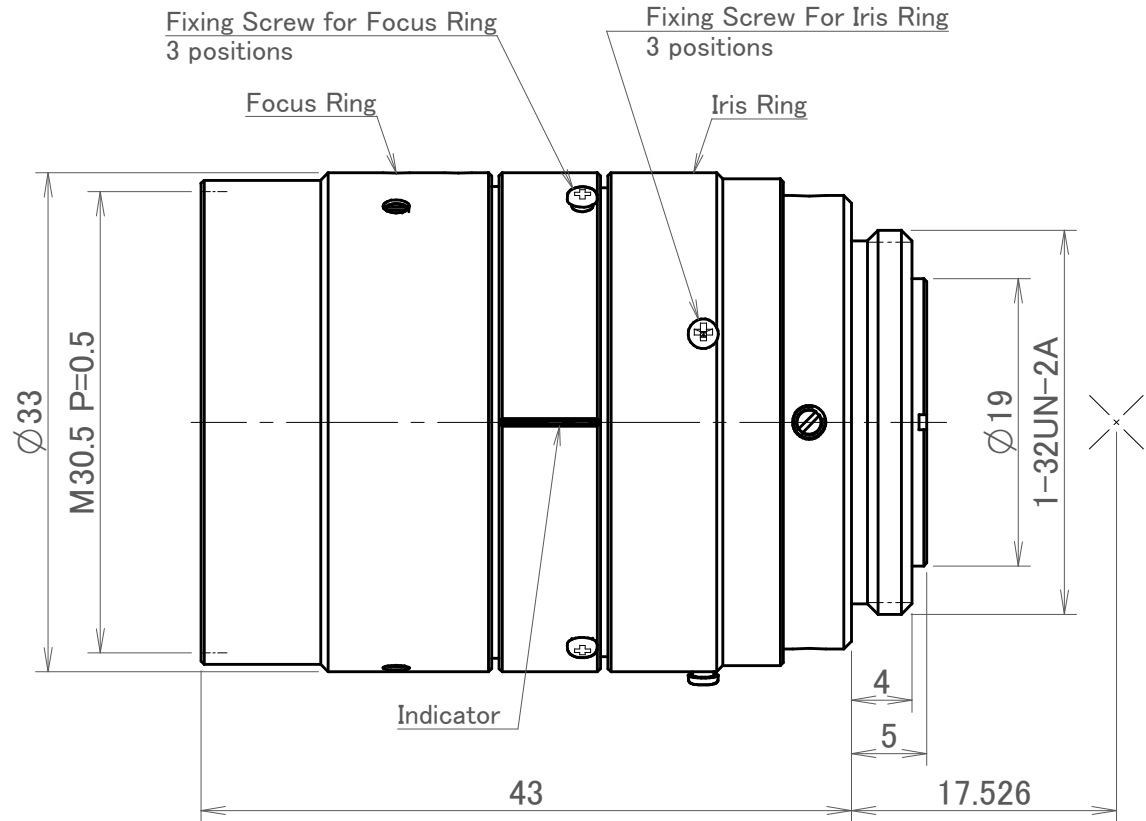
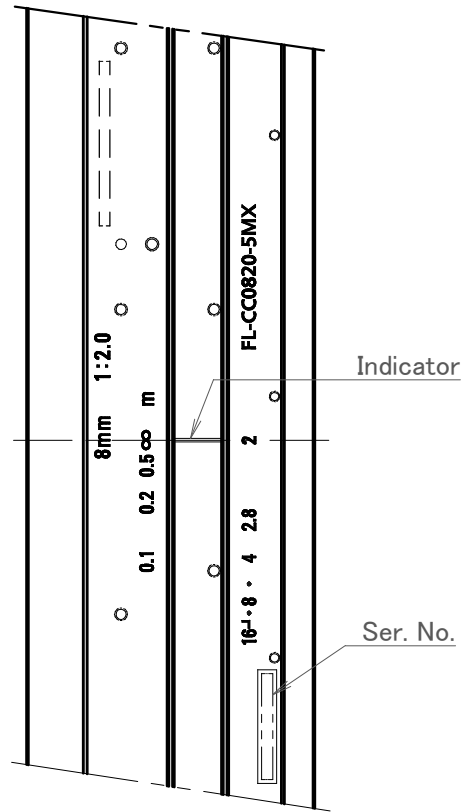

**Vision Light Tech**  
creating optical solutions

Vision Light Tech B.V.  
Protonenlaan 22, 5405 NE UDEN, P.O. Box 345, 5400 AH UDEN, The Netherlands  
Phone: +31 (0)413 26 00 67, Fax +31 (0)413 26 09 38, E-mail: inquiry@vlt.nl, Website: www.vlt.nl  
Trade register No. 17150044, VAT No. NL8112.30.946.B01